

post top luminaire

CLEO I DA LED ZSo

with Zhaga socket



- recom. pole height: 3.00m – 5.00m
- light standards: for low and medium lighting requirements
- lamp: incl. 1 DA+ LED module, easy to replace
- colour temperature: 3.000K warm white or 4.000K neutral white
- surge protection: 10kV
- LED gear: incl. programmable, Zhaga Book18 compliant and D4i-certified driver with DX or SR interface and data communication, incl. integrated Zhaga sockets TOP in order to retrofit standardised light management systems, e.g. CLEVER LIGHT, CityTouch or Easy Air, driver life expectancy: up to 100,000 hours
- LED life expectancy: 65,000 hours/ L100/ B10; 100,000 hours/ L90 /B10 for minimum maintenance costs due to an excellent thermal management
- light control: at extra cost: dimming, power reduction, DALI future-proof Zhaga socket in the cap, suitable for retrofitting the luminaire with Hub light control systems, e.g. CLEVER LIGHT, CityTouch Ready, i.a.
- optical system: lens technology; incl. anti-glare protection
- light distribution: oval wide beam
- luminaire head: made of cast aluminium and aluminium; base made of die cast aluminium; powder coated
- colour: DB 703; other RAL or DB colour without extra cost on request
- glazing: polycarbonate, impact resistant, UV-stabilised; clear with with additional satined diffuser inside for soft light
- wiring: completely wired; incl. cabel 5.00m max. 3 x 1mm²
- installation: for top entry ø 60mm
- accessories: pole, pole accessories, back light shield for non-glare on the rear side – to be ordered separately
- application areas: residential and local distributor roads, car parks, schools, hotels, factory premises, paths, squares, parks

lamp	kg	product code
Zhaga socket TOP, CityTouch conform		
DA+ LED 12W/2,000lm/3,000K	19.0	5.904.9115.05068-3-9ZSo
DA+ LED 14W/2,300lm/3,000K	19.0	5.904.9118.05068-3-9ZSo
DA+ LED 18W/2,900lm/3,000K	19.0	5.904.9124.05068-3-9ZSo
DA+ LED 12W/2,100lm/4,000K	19.0	5.904.9115.05068-9ZSo
DA+ LED 14W/2,400lm/4,000K	19.0	5.904.9118.05068-9ZSo
DA+ LED 19W/3,000lm/4,000K	19.0	5.904.9124.05068-9ZSo
data transmission to the cloud		2.919.0100.21
power reduction without pilot-line, dimming level and time according to customer's request		5.904.xxxx.05068(-3)-9ZSo-93
power reduction with pilot-line, dimming level and logic according to customer's request		5.904.xxxx.05068(-3)-9ZSo-94
accessory: CLEVER LIGHT		
CLEVER LIGHT HUB BASIC		2.919.0100.17-B03
CLEVER LIGHT HUB GPS-C		2.919.0100.17-GPS-C
accessory: back light shield		
LS DA 1		2.914.8301.17

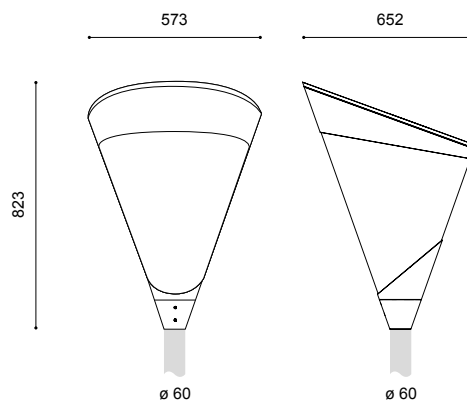

class II at extra cost (add "S" at the end)

Technical specifications are subject to change without notice. 09.2022