

recessed luminaire

# EL THOMAS II PL-LS LED

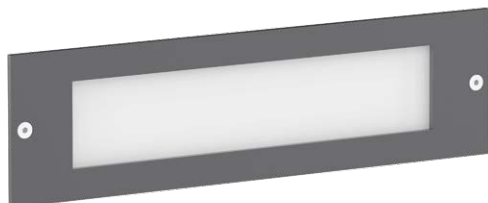

- recommended height: 0.2m – 1.00m
- light standards: low lighting requirements
- lamp: incl. PL-LS LED module
- colour temperature: 3,000K warm white or 4,000K neutral white
- LED gear: incl. driver; up to 100,000 hours
- LED life expectancy: 65,000 hours/ L100/ B10; 100,000 hours/ L90/ B10 for minimum maintenance costs due to an excellent thermal management
- optical system: horizontal PL-LS LED module; satined cover with external louvre system for directed light downwards
- light distribution: asymmetrical
- luminaire body: small luminaire body in the size of a standardised brick, made of stainless steel V2A (304); powder coated
- colour: DB 703; other RAL or DB colour without extra cost on request
- glazing: glazing made of PMMA, satined, impact resistant, UV-stabilised; without decorative grille
- wiring: completely wired; with free cable ends for customer connection, length 0.5m
- installation: to be set into the wall by using the installation box (EBK 252/69)
- accessory: installation box (required for installation), fixing material for the wall installation
- application areas: elegant, harmonic wall luminaire for entrances and ways along houses; for hotels, factory premises, schools, home for elderly people, private residences

lamp	kg	product code
PL-LS LED 3,5W/620lm/3.000K	3,8	9.025.7290.0208-3
PL-LS LED 4,5W/810lm/3.000K	3,8	9.025.7291.0208-3
PL-LS LED 6W/1.010lm/3.000K	3,8	9.025.7292.0208-3
PL-LS LED 3,5W/660lm/4.000K	3,8	9.025.7290.0208
PL-LS LED 4,5W/880lm/4.000K	3,8	9.025.7291.0208
PL-LS LED 6W/1.090lm/4.000K	3,8	9.025.7292.0208

**necessary accessory**

installation box EBK252/69	1,0	9.903.3805.00
----------------------------	-----	---------------

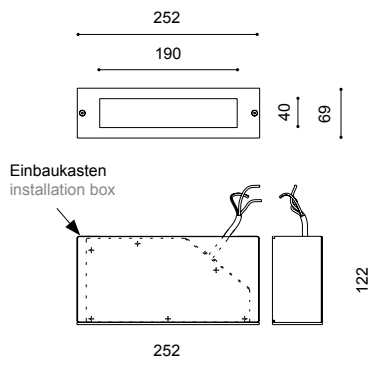

Schutzklasse II gegen Mehrpreis (Buchstabe "S" am Ende der Bestellnummer ergänzen)

Technical specifications are subject to change without notice. 01.2026